

概述 Overview

电动单座（套筒）调节阀形小体轻，性能优良，是高品质的基型电动调节阀产品。它适用于一般流体介质工艺条件的生产过程控制系统。

The electric single-seat (sleeve) adjustment valve is small in size and excellent in performance, and is a high-quality base type electric control valve product. It is suitable for production process control systems for general fluid media process conditions.

本产品由3810L系列电子式电动执行机构和精小型单座（套筒）调节阀组成。执行机构含有内置式电子控制器模块的一体化结构，可免去另配用伺服放大器麻烦。它的精度高，装校简便。套筒阀特点如下：

This product consists of 3810L series electronic electric actuator and small single seat (sleeve) regulating valve. The actuator has an integrated structure with built-in electronic controller modules, eliminating the need for additional servo amplifiers. It has high precision and is easy to install. The characteristics of the sleeve valve are as follows:

1.采用平衡型阀芯，不平衡力小，允许压差大，操作稳定；

Adopting balanced valve core, the unbalanced force is small, the pressure difference is allowed to be large, and the operation is stable;

2.阀芯导向面大，可改善由涡流和冲击引起的振荡，并减少损坏；

The large guide surface of the spool improves the oscillation caused by eddy currents and shocks and reduces damage;

3.比普通单双座阀调节阀噪声降低10dB左右

The noise of the ordinary single and double seat valve regulating valve is reduced by about 10dB.

4.结构简单，装拆维修方便

Simple structure, convenient assembly and disassembly

单座阀具有可靠的动作特性，微小的阀座泄漏，粗确定的流量特性，宽大的可调范围，结构紧凑，流道畅通。

The single seat valve has reliable operating characteristics, small seat leakage, coarse flow characteristics, wide adjustable range, compact structure and smooth flow path.

本系列产品性能好，操作稳定，能在广泛的应用中满足用户的控制需要。

This series of products has good performance and stable operation, and can meet the user's control needs in a wide range of applications.

主要技术参数及性能指标 Main technical parameters and performance indicators

1. 主要技术参数

Main technical parameters

公称通径 mm Nominal diameter	25	40	50	65	80	100	150	200	250	300	
额定流量系数Kv Rated flow coefficient Kv	直线 Straight line	6.9 11	17.6 27.5	27.5 44	44 69	69 110	110 176	275 440	440 690	690 1000	1000 1600
	等百分比 Equal percentage	6.3 10	16 25	25 40	40 63	63 100	100 160	250 400	400 630	630 900	900 1400
额定行程 mm Rated stroke	16	25	40	60	100						
执行机构型号 Actuator model	381LSA-20	381LSB-30	381LSB-50	381LSC-65	381LSC-99						
允许压差MPa Allow differential pressure	6.4				4.2	4.6	3.7	2.7	2.2		
控制信号 Control signal	4~20mA d.c., 1~5V d.c.										
电源 Power supply	220V a.c., 50Hz										
公称压力 MPa Nominal pressure	1.6、4.0、6.4										
工作温度℃ Operating temperature	WCB: -40~250、-40~450 Stainless Steel: -40~250、-60~450										
固有流量特性 Intrinsic flow characteristics	直线、等百分比 (固有可调比50:1) Straight line, equal percentage (inherent adjustable ratio 50:1)										

注：对于选定的公称口径，若无用户指定，均供应最大Kv值产品，如需比表列更小的Kv值产品，可与本公司商洽解决。如需超出表列工作温度范围的产品，可与本公司商洽解决

Note: For the selected nominal diameter, if there is no user binding, the maximum Kv value product is supplied. If the Kv value product is smaller than the listed one, you can negotiate with the company.

For products that exceed the operating temperature range of the table, you can negotiate with the company.

2、①主要技术性能指标 (套筒阀)

Main technical performance indicators (sleeve valve)

基本误差: ±1.0%  
Basic Error: ±1.0%

回差: 1%  
Backlash: 1%

死区: 1%  
Dead Zone: 1%

泄漏量:  $5 \times 10^{-3}$  阀额定容量  
Leakage:  $5 \times 10^{-3}$  Valve rated capacity

额定流量系数: ±10%  
Rated flow coefficient: ±10%

固有流量特性: 斜率 ±30%  
Intrinsic flow characteristics: Slope ±30%

②主要技术性能指标 (单座阀)

Main technical performance indicators (single seat valve)

基本误差: ±2.5%  
Basic Error: ±2.5%

回差: 1.5%  
Backlash: 1.5%

死区: 3%  
Dead Zone: 3%

泄漏量:  $1 \times 10^{-4}$  阀额定容量  
Leakage:  $1 \times 10^{-4}$  Valve rated capacity

额定流量系数: ±10%  
Rated flow coefficient: ±10%

固有流量特性: 斜率 ±30%  
Intrinsic flow characteristics: Slope ±30%

主要零件材料 Main part material

阀体/阀盖: ZG230-450、ZG1Cr18Ni9Ti, ZG0Cr18Ni12Mo2Ti, 或相当的美国牌号 WCB, CF8, CF8M  
 阀芯, 套简单座: 1Cr18Ni9Ti, 0Cr18Ni12Mo2Ti, 或相仿的美国牌号304, 316 (特殊材料或堆焊史太立合金可商洽)

填料: 聚四氟乙烯, 柔性石墨

Valve body: ZG230-450、ZG1Cr18Ni9Ti, ZG0Cr18Ni12Mo2Ti, Or equivalent US brand WCB, CF8, CF8M  
 Spool, sleeve single seat: 1Cr18Ni9Ti, 0Cr18Ni12Mo2Ti, Or similar US grade 304, 316  
 (special materials or surfacing welding history can be negotiated)

Filler: Polytetrafluoroethylene, flexible graphite

尺寸和重量 Size and weight

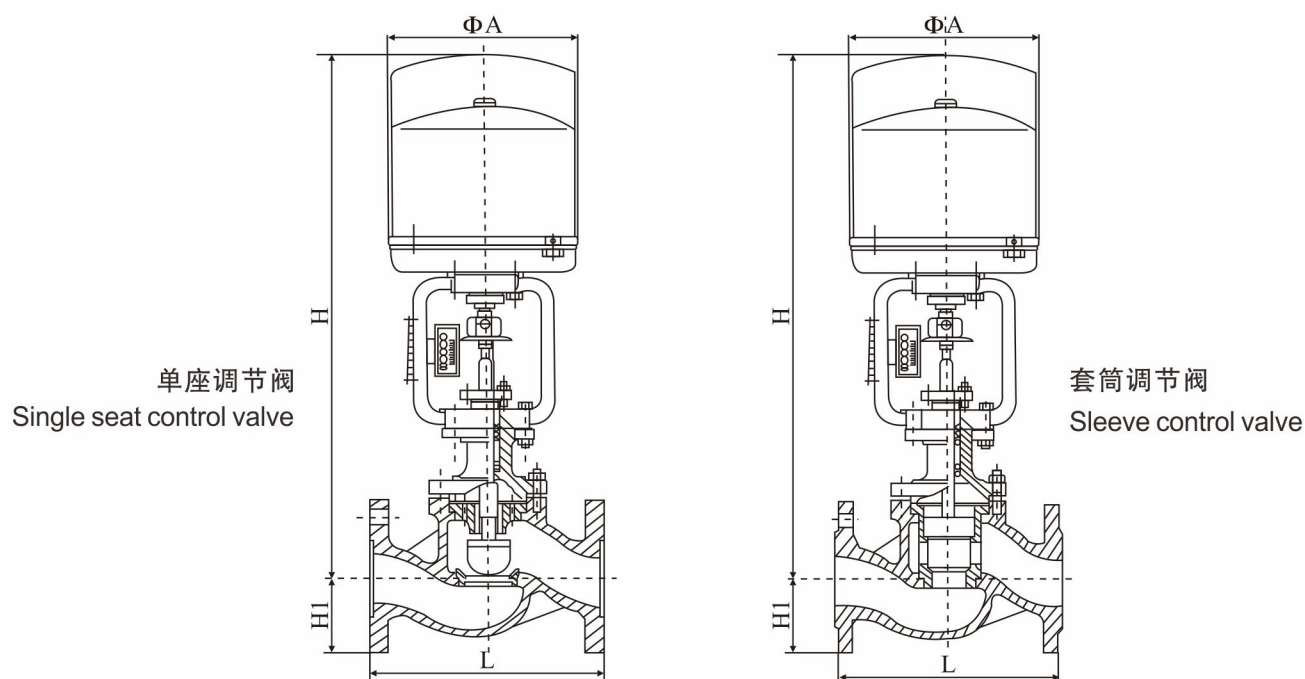

1、外形尺寸和重量 Dimensions and weight

DN	L			H		H1			$\Phi A$	重量 weight kg	
	PN16	PN40	PN64	普通 Ordinary	高温 High	PN16	PN40	PN64		PN16	PN40 PN64
25	184	197	210	503	653	57		70	260	15	19
40	222	235	251	648	813	75		85		26	35
50	254	267	286	650	820	82		90		30	40
65	276	292	311	752	932	92		102		34	53
80	298	317	337	764	949	100		107		42	65
100	352	368	394	782	992	110	117	125	360	52	86
150	451	473	508	1077	1337	142	150	172		152	206
200	600		650	1097	1357	170	187	207		220	280
250	730		775	1240	1560	202	225	235		423	470
300	850		900	1271	1591	230	257	265		663	735

## 2、法兰连接尺寸 Flange connection size

本产品法兰连接尺寸符合  
凸面整体铸钢管法兰  
凹凸面整体铸钢管法兰  
根据用户特殊要求，本产品也可按其他国内外法兰标准制造

The flange connection dimensions of this product are:

Convex integral cast steel pipe flange

Concave surface integral cast steel pipe flange

According to the special requirements of users, this product can also be manufactured according to other domestic and foreign flange standards.

### 产品型号 Product number

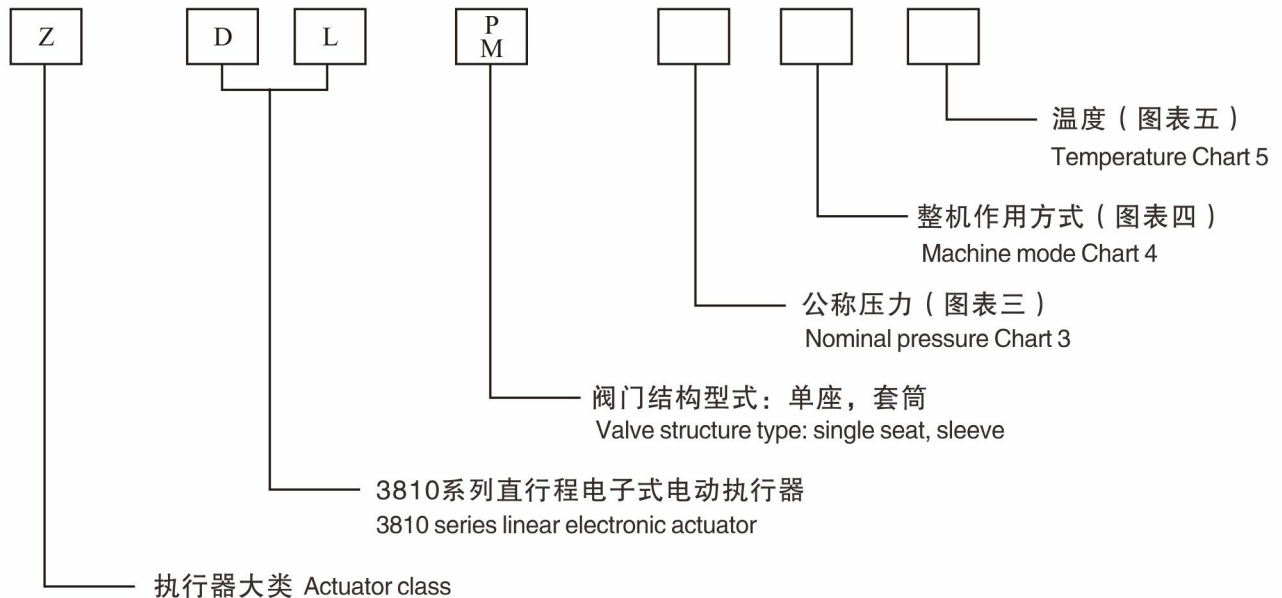

图表三 Chart 3

公称压力 Nominal pressure MPa	0.6	1.6	4.0	6.4
代号 Code	6	16	40	64

图表四 Chart 4

整机作用方式 Machine mode	电开式 Electric opening	电闭式 Electric closed
代号 Code	K	B

图表五 Chart 5

温度 temperature	常温 Normal temperature	中温 Medium temperature	低温 Low temperature
	-20~+200 °C -40~+200 °C	-40~+450 °C	-250~-60 °C
代号 Code	无	G	D